

REVISIONS					
REV.	ECN NO.	LOCATION	DESCRIPTION	DATE	DESIGN
X1	N/A		INITIAL RELEASE	2014.12.10	

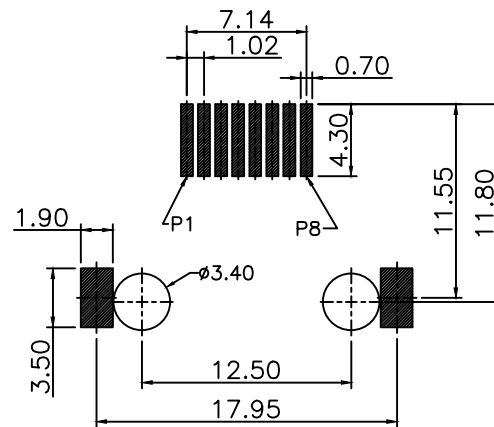
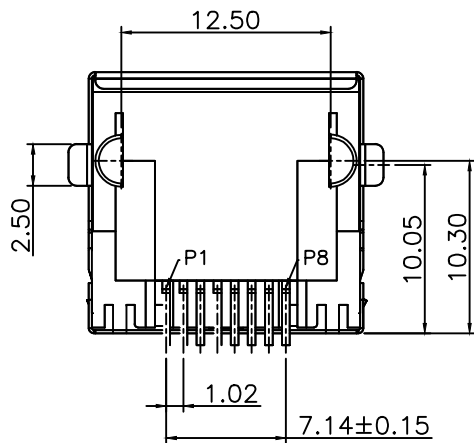
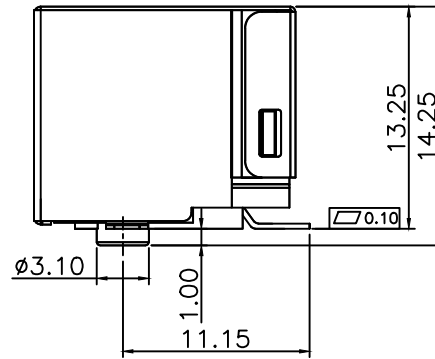
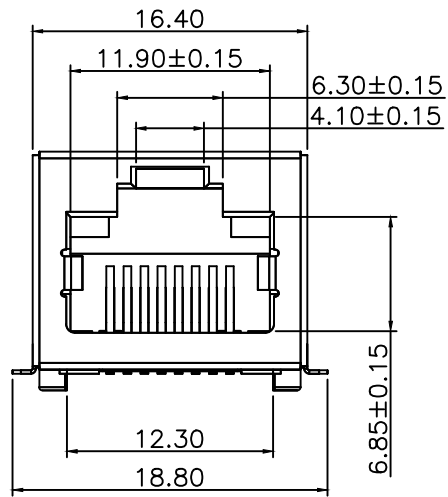

RECOMMENDED PCB LAYOUT  
PTOLERANCE=±0.05

**SPECIFICATION NOTES:**

**ELECTRICAL:**

- 1.VOLTAGE RATING: 125 VAC RMS
- 2.CURRENT RATING: 1.5 AMP
- 3.CONTACT RESISTANCE: 20mΩ MAX.
- 4.INSULATION RESISTANCE: 1000MΩ MIN. AT500V DC.
- 5.DIELECTRIC STRENGTH: 1000 V AC OR 1500V DC RMS AT 0.5mA 50 Hz / 60 Hz FOR 1MINUTE

**MECHANICAL:**

- 1.HOUSING:LCP BLACK, UL 94V-0
- 2.CONTACT:PHOSPHOR BRONZE T=0.30MM
- 3.PLATING:GOLD PLATING AT CONTACT AREA, MATTE TIN AT TAIL 100U MIN., NICKEL 30U MIN. OVER ALL.
- 4.SHELL:BRASS T=0.20
- 5.OPERATING LIFE:750 CYCLES MIN.
- 6.MATING/UNMATING FORCE: 30N/3.06KgF MAX.
- 7.RETENTION STRENGTH:50N OR 30N MIN.FOR 60S±5S

**ENVIRONMENTAL:**

- 1.STORAGE:-40°C TO +85°C RELATIVE HUMIDITY<80%
- 2.GUARANTEE PERIOD:12 MONTHS
- 3.OPERATION: -40°C TO +85°C
- 4.MANUAL SOLDERING PARAMETERS:24H IR TEMPERATURE: 260±5°C 5~10 SECONDS.

MEASURE POINT:	(xx)
QUADRANT POINT	(QP)
TANGENCY POINT	(TP)
INTERSECTION POINT	(IP)

UNLESS OTHERWISE SPECIFIED, TOLERANCE:	
X.	±0.25
X.x	±0.15
X.xx	±0.10
X.xxx	±0.05
ANGLES	±1°

**Coorle 库乐科技**

DESIGN	DATE 12/12'2014	TITLE: <b>RJ45 SMT</b> (无LED灯铜壳无弹片胶芯柱平行)
CHECKED	DATE	PAPT NO: HL RJ45 884-810-4
APPROVED	DATE	REV.: X1 SCALE: UNIT: mm
PART NO.		SIZE: A4 SHEET: 1/1
DRAWING NO.		